

PARTS LEGEND IM200/50 S16 SOLID STATE, 900078

1	900356	1	Grill	58	091532	1	Negator
2	900455	1	Filter	59	091534	1	Drum, Negator
3	901065	4	Shoulder Screw, 10-24 x 1-1/4	60	402743	1	Pin, Negator Drum
4	008388	4	Flat Washer #10	61	402668	1	Retaining Washer
5	900410	1	Cap Assembly	62	402796	1	Follower
6	404427	3	Screw, Taptite, 8-32 x 5/8	63	403104	1	Air Dam
7	006562	3	Washer #8	64	403100	1	Combustion Chamber Assembly
8	900271	1	Circuit Board Assembly	65	403099	1	Retaining Ring, Piston
9	900526	1	Motor & Connector	66	403098	1	Piston Ring
10	403842	1	Spark Plug Boot	*67	404665	1	Piston Driver Blade Assembly
11	401341	1	Spark Plug Assembly	68	403094	1	Bumper
12	401356	1	Sleeve, Motor	69	403084	1	Sleeve/ Midcheck Ring Assembly
13	900470	1	Motor Mount Assembly	70	403089	1	Seal Washer
14	401355	1	Retaining Ring	71	403090	2	Wave Washer
15	403146	1	Stem Adapter (Yellow)	72	403092	2	Retaining Ring, Midcheck
16	900004	1	Cylinder Head	73	403091	1	Muffler
*17	404700	2	O-Ring	74	404339	1	Spring, Chamber Return
18	403167	1	Fan Blade Assembly	75	403106	1	Cage
19	900011	1	Battery Contact Assembly	76	403713	3	E-Ring, Retaining
20	900968	2	Shoulder Screw, 10-32 x 9/16	77	404316	1	Flange, Sleeve
22	404432	1	Bushing, Actuator	78	900411	1	Housing Assembly
23	900357	1	Actuator	▲80	004174	2	S. H. C. S. 10-24 x 7/8
24	404433	1	Pin, Actuator	81	900534	2	S. H. C. S. 10-32 x 5/8
25	900136	1	Actuator Assembly	82	092037	1	Locknut, 10-32
27	900179	1	Handle Right Side	83	402736	1	Washer, Flat #10 Black
28	403156	1	Lanyard	84	404319	1	Lower Work Contacting Element
29	403155	1	Battery Cap	85	900056	1	No-Mar Tip (Optional)
30	900138	1	Handle, Left Side	86	004238	1	Lockwasher #10
32	900453	3	Thrd. Frm.Screw, 8-16 x 7/8	87	402629	1	Washer, Hardened #10
33	900289	1	Belt Hook	88	900535	1	Upper Work Contacting Element
34	901221	1	Screw, 8-32 x 9/16	89	404365	1	Front Guide
35	403082	1	Washer	▲90	900537	2	S. H. C. S. 10-24 x .813
36	403166	1	Bushing	91	900550	1	Back Plate
37	401450	2	Pad, Fuel Cell	92	403822	1	Pivot Pin
38	402201	2	Screw, Phillips Head, 2-56 x 5/8	93	900001	1	Spring, Latch
39	404490	1	Trigger Switch Assembly	94	404317	1	Latch, Front Guide
40	401395	1	Spring	95	092176	1	Roll Pin, 5/32 Dia. x 1-3/8
41	900358	1	Trigger	96	404315	1	Flange, Nose
42	403127	1	Retention Cap	97	900583	1	Removable Spark Plug Wire
43	001641	1	Nut, 8-32	98	900280	1	Spark Assembly
44	900562	1	S. H. C. S. 10-24 x 1-1/8"	99	900509	1	Nameplate
45	900552	2	Cover Plate	100	404385	1	Light Pipe
▲46	004224	5	Screw	**101	900496	1	Warning Label
47	900549	1	Rail Bracket	103	900651	2	Label, Logo
48	404698	2	Roll Pin Assembly	**104	900517	1	International Warning Label
49	900551	1	Pivoting Rail Cover Assembly	106	900232	1	Cable Clamp
50	900548	1	Rail & Cover Assembly	107	404601	1	Head Switch Assembly
51	900532	1	Lower Siding W. C.E.	108	900166	1	Spring, Combusion Chamber
▲52	402797	1	Retaining Bushing	109	900164	1	Ring, Head Switch Activating
53	402798	1	Latch, Follower Button	110	900182	2	Washer, Trigger
54	402799	1	Spring, Follower Latch	111	900142	1	Label, Battery
55	402740	1	Roll Pin, 3/32 x 7/16	112	900236	1	Clip Handle
56	091568	1	Screw, Pan Head, 6-32 x 1/4	114	900300	1	Retaining Ring
57	070545	1	Lockwasher #6	115	900468	1	Washer

* Denotes normal wear items.

** Make sure warning labels are properly affixed, replace if necessary. Labels available at no charge through the Service Department.

▲ Apply Loctite 242 (Blue).

→ Denotes new change.

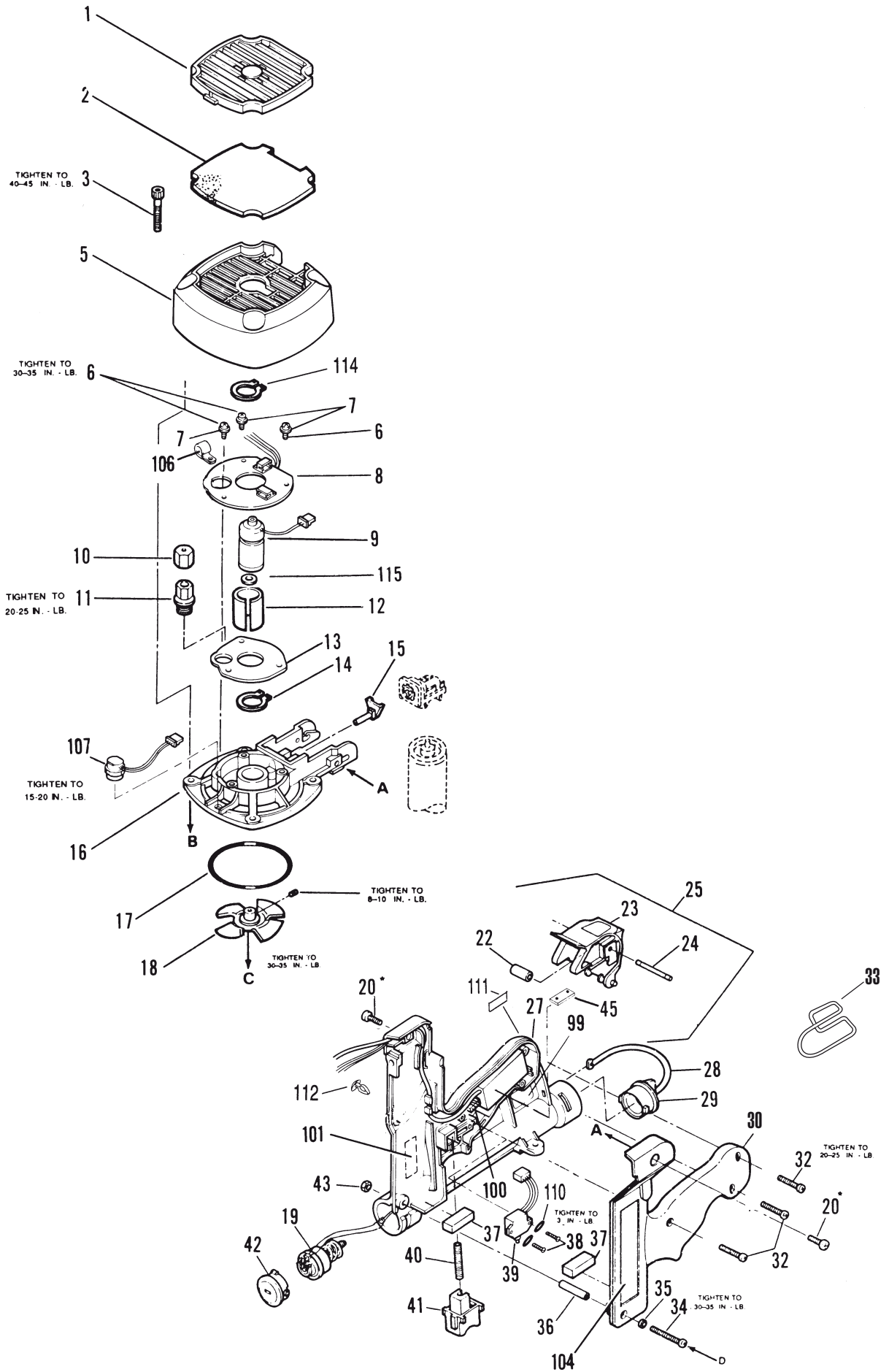

**IM200/50 S16
SOLID STATE
900078**

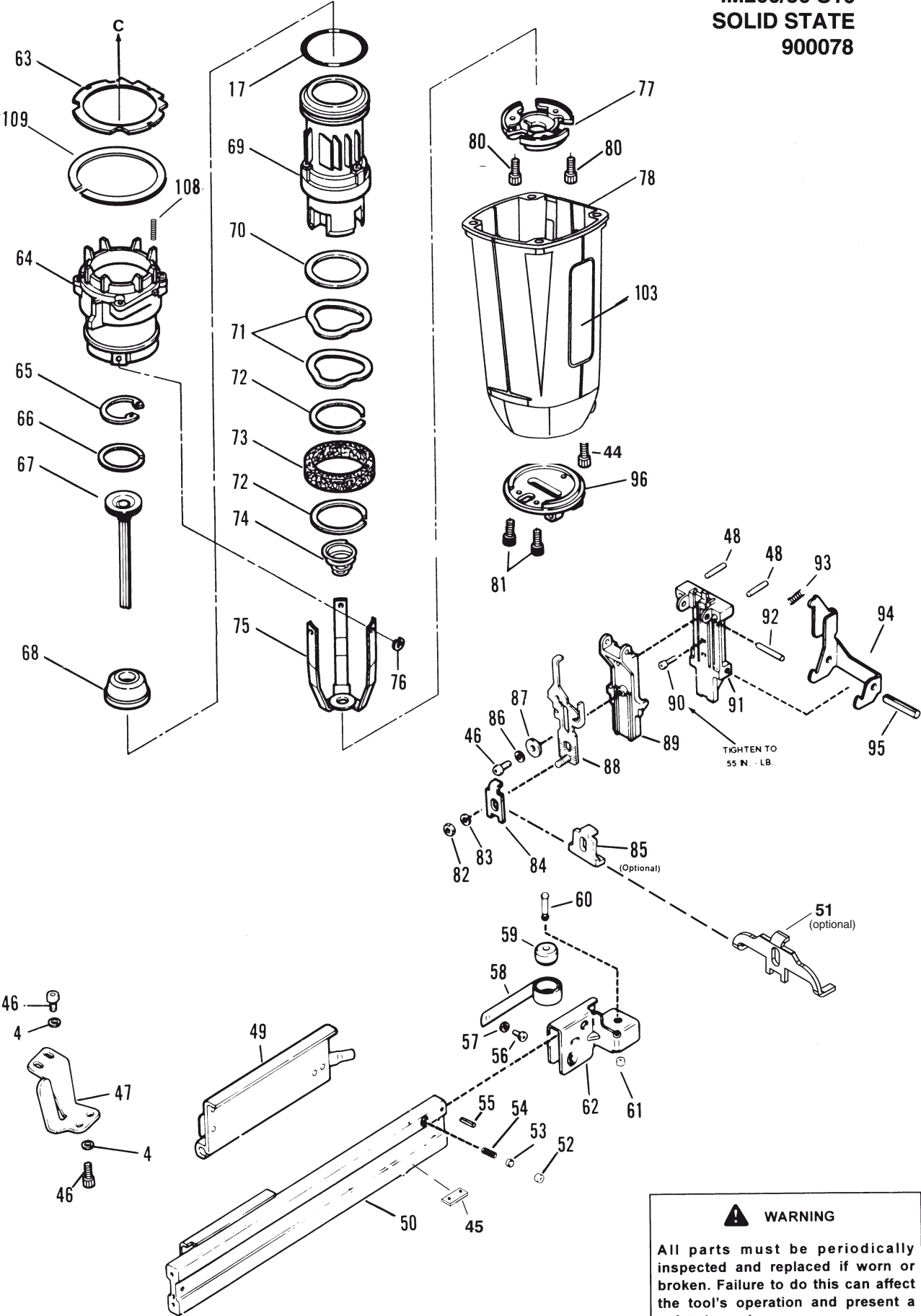

⚠ WARNING

All parts must be periodically inspected and replaced if worn or broken. Failure to do this can affect the tool's operation and present a safety hazard.